

SPECIFICATIONS

Size	Metric	British
Max. Working Height A	22.00m	72ft 2in
Max. Platform Height B	20.00m	65ft 7in
Overall Length C	4.72m	15ft 6in
Overall Width D	1.25m	4ft 1in
Overall Height(Rails Up) E	3.82m	12ft 6in
Overall Height(Rails Down) F	2.99m	9ft 10in
Platform Size(Length×Width)	4.30m×1.19m	14ft 1in × 3ft 11in
Platform Extension Size G	1.80m	5ft 11in
Ground Clearance(Stowed/Raised)	0.20m/0.02m	8in/1in
Wheelbase H	3.18m	10ft 5in
Turning Radius(Inside/Outside)	1.6m/2.3m	5ft 3in/7ft 7in
Tyres	28×10-22	28×10-22

Performance		
S.W.L	750kg	1653lb
S.W.L On Extension	750kg	1653lb
Max. Occupants	2	2
Gradeability	25%	25%
Travel Speed(Stowed)	3.0km/h	3.0km/h
Travel Speed(Raised)	0.5km/h	0.5km/h
Max. Working Slope	1°(0°)	1°(0°)
Up/Down Speed	85/75sec	85/75sec

Weight		
Overall Weight	12350kg	27227lb

Power		
Hydraulic Tank	130L	130L
Battery	48V/630Ah	48V/630Ah
Charger	48V/60A	48V/60A
Driving Motor	4×AC 32V/3.3kW	4×AC 32V/3.3kW
Lifting Motor	2×DC 48V/8.0kW	2×DC 48V/8.0kW

* The platform height plus 2m (7ft in British standard) is the working height.
Standards Compliance

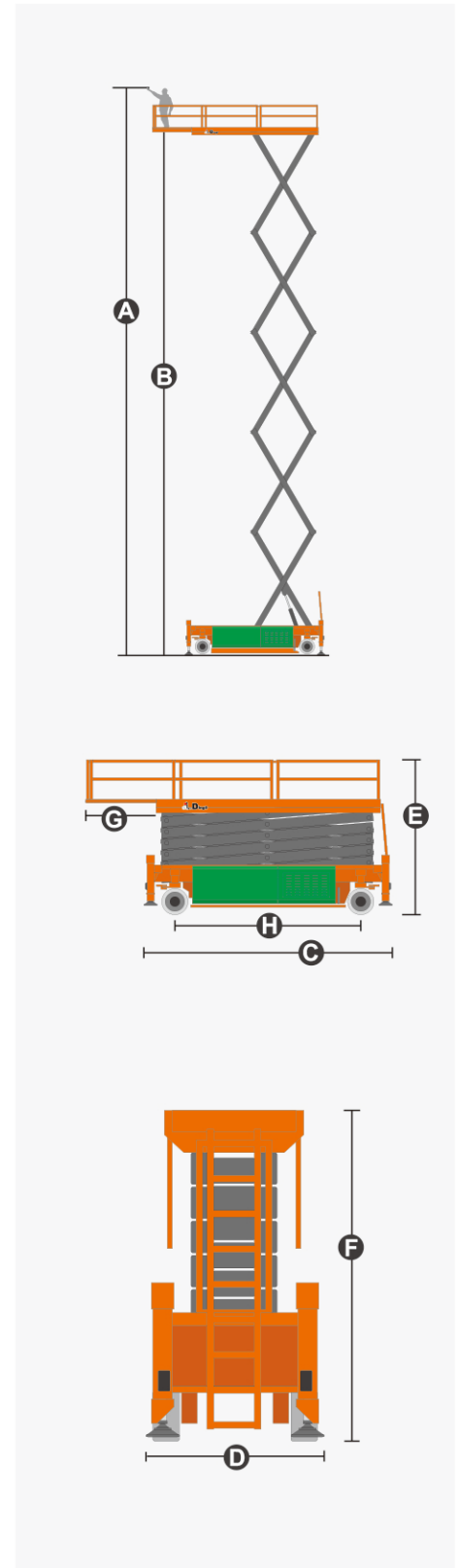

FEATURES

Standard Items

- Proportional Joystick Controls
- Self-Locking Gates
- One-Way Platform Extension Deck
- Drivable At Full Height
- Solid Rubber Tyres
- 4×4 Drive
- 4×4 Steer
- Four-Wheel Braking
- Self-Weight Lowering System
- Tubing Explosion-Proof System
- Onboard Fault Diagnostic System
- Tilt Alarm
- Motion Alarm
- Horn
- Hour Meter
- Charging Protection System
- Flashing LED Beacon
- Foldable Guard Rails
- Drive Enable
- Platform Load Sense System
- Manual Brake Release
- Lanyard Attachment Point
- Tie-Down And Lifting Points
- Automatic Leveling Hydraulic Outriggers
- Emergency Pump
- Emergency Stop Button

Optional Items

- Factory Hydraulic Oil**
- No. 46 Hydraulic Oil (Mineral Oil)**

Additional Items

- GPS Unit
- Biodegradable Hydraulic Oil
- AC Power Cord to Platform
- Air Line to Platform
- Work Light Package
- Footpedal Switch
- Anti-Collision Bar on Platform
- Visual Spirit Level
- Outrigger Pad Package
- Guard Mesh Package
- Self-Lubrication System

** Factory Default, If You Have Other Needs, Please Inform Dingli Regional Sales.

ZHEJIANG DINGLI MACHINERY CO., LTD.

No.188 Qihang Road,Deqing,Zhejiang P.R.China 313219

Telephone +86(572)8681688

Fax +86(572)8681960

E-Mail export@cndingli.com

[Http://www.cndingli.com](http://www.cndingli.com)

